

Preliminary Design of the Beam Loss Monitoring System for the SNS

R. Witkover*, D. Gassner

*BNL, Upton, NY; *TechSource Inc., Santa Fe, NM*

Abstract. The SNS to be built at Oak Ridge National Laboratory will provide a high average intensity 1 GeV beam to produce spallation neutrons. Loss of even a small percentage of this intense beam would result in high radiation. The Beam Loss Monitor (BLM) system must be sensitive to low level, long term losses, and be capable of measuring infrequent short high losses. This large dynamic range presents special problems for the system design. Ion chambers will be used as the detectors. A detector originally designed for the FNAL Tevatron, was considered but concerns about ion collection times and low collection efficiency at high loss rates favor a new design. The requirements and design concepts of the proposed approach will be presented. Discussion of the design, testing of the ion chambers, and the analog front end electronics will be presented. The overall system design will be described.

BACKGROUND

The Spallation Neutron Source (SNS)¹ is an accelerator based intense neutron source being built at Oak Ridge National Laboratory (ORNL) by a collaboration of 6 national laboratories. The controls and some beam instrumentation were consolidated so that the same detectors and interface hardware would be used throughout the facility to minimize costs and reduce uncertainty due to different instrumentation. BNL has responsibility for the beam loss monitoring system for all of SNS. The SNS H-minus ion source will inject a 60 Hz chopped beam into a 2.5 MeV RFQ. After acceleration to 87 MeV in a Drift Tube Linac (DTL), the beam enters the Cavity Coupled Linac (CCL), leaving at 186 MeV. The Superconducting RF Linac (SRF) will increase the beam energy to 1 GeV. The beam is transported to the Ring via HEBT, converted to protons using a stripping foil, and accumulated in a single 695 nsec bunch over the 1 msec injection pulse. The bunch is transported via the RTBT line to the spallation neutron target. The design peak beam current in the Linac and HEBT will be 38 mA. In the Ring it will increase to more than 40 A (average) at the end of the pulse, for a total of 1.5×10^{14} protons in the single bunch. The BLM system will be designed to accommodate an upgrade intensity of 2×10^{14} protons.

The baseline design will produce 1.4 MW at a 60 Hz rate. This very high average beam power makes it crucial that uncontrolled losses do not produce high activation, preventing hands-on maintenance. This will be done by minimizing losses through

Work performed under the auspices of the U. S. Dept. of Energy

careful design and providing beam dumps and collimators where controlled losses can be contained. The BLM system must minimize uncontrolled losses by providing data for tuning the machine and inhibiting the beam when excessive losses occur.

SYSTEM PHILOSOPHY AND DESIGN

The BLM's will be the primary tool for limiting uncontrolled losses by providing sufficient detector coverage in all sections of the SNS. To achieve this the BNL AGS Linac and Ring use extended ion chambers made from hollow argon-filled, large diameter coaxial cables². At ISIS, a machine similar in function to SNS, the same type detectors have been used³. A "line" detector has 1/r spatial dependence, but its length often prevents close coupling to the beam line, lowering the response. Since losses predominantly occur at the quad, most of the detector receives a much lower exposure, reducing the benefit of the greater length. The standard connectors for these cables cannot support high bias voltage, limiting the linear range to lower dose rates. For these reasons smaller, sealed glass ion chambers designed for the FNAL Tevatron were used in RHIC⁴, but more detectors were required to obtain similar coverage. In the SNS Linac, HEBT, Ring and RTBT, as in RHIC, detectors will be placed at essentially every quadrupole (beta-max) and at other key points. Provision will be made for a number of movable BLMs which can be used for more detailed study.

Ion chambers were chosen as the primary distributed detector over solid state (pin diode) and scintillator-photomultipliers. A commercial pin-diode BLM⁵ is available but the 10 MHz maximum output rate would not provide the dynamic range required during a 1 msec beam pulse. Scintillator-photomultipliers do not have the long term stability needed for an accelerator application. However, to be able to see losses within the bunch, scintillator-photomultipliers will be installed at a limited number of points, such as, Ring injection and extraction, and other strategic points. Since only a relative time history is of interest for this application, non-calibrated data is acceptable.

System Requirements

High level losses over several pulses can quench or damage the super-conducting cavities in the SRF Linac. Low level losses can prevent "hands-on" maintenance. To avoid this, losses must be limited to 1 W/m averaged over several seconds duration, roughly equivalent to 10^{-4} of a 2 MW beam lost uniformly around the Ring. Dynamic range must be available to measure such long-term low level losses, yet not saturate under short duration, high level losses. The BLM system will provide hardware and software generated signals to indicate excessive loss and data for tuning the beam to reduce operating losses. These considerations lead to the requirements shown below.

Detailed time history. Data within a macro-pulse will be acquired at 100 kSa/S per channel but will be packed at the front-end computer (IOC) and transmitted at a 6 Hz rate.

Total loss for each BLM per macro-pulse. The data from each BLM will be summed at the IOC and transmitted once per second. This data may be presented as a “waterfall” display⁶ which shows the long-term history with detector location as the horizontal axis, time as the vertical axis, and level as color. A simple x-y plot of location versus loss, updated at a few Hz, will be available. The losses for each BLM will be kept in a 1000 point FIFO history at the console level for use in the event of an abort.

Long-term, low-level beam loss alarm and display. The long-term, low-level beam loss (< 1 W/m) will be averaged over 10 seconds in the IOC and compared against a 1 W/m reference. Warnings will be sent as this level is approached and an alarm when it is exceeded. The pre-averaged low-level data will be available as a waterfall display or a strip chart style display.

Fast loss output for the Machine Protect System. Each BLM electronics channel will provide an output signal to the Machine Protect System (MPS) to shut off the beam in the event of a high-level beam loss. This signal will be derived in hardware from the integrated beam loss during the macro-pulse and shall occur within 10 μ sec of the loss. Each channel shall have masking capability in the MPS to allow the use of diagnostic hardware which can cause beam loss, such as wire scanners. The mask will also permit studies which might generate a higher than normal local beam loss, and disable malfunctioning BLM channels which would prohibit beam operation. A beam inhibit signal shall also be generated if the integrated loss for any BLM over a 1 second period exceeds a preset limit. This shall be done in software at the IOC and executed through an MPS line in the Utility Module.

Gain setting and readback for each BLM. Each BLM electronics channel will have 3 jumper selectable gain settings to compensate for high radiation locations, such as at dumps, injection, extraction, and the collimators, or lower loss locations such as lower energy regions and well shielded areas. The “Viewing Gain” for the wideband-output can be changed (x1, x10) via the control system without affecting the fast loss trip or the 1 W/m level sensing. Gain setting may be required pulse-to-pulse to allow for different mode cycles, but not during the macro-pulse. Read back of the jumper-selectable gain and Viewing Gain states will be provided.

Bias voltage control. During studies periods, it may be necessary to vary the detector bias voltage. Readback of the voltage and current will be needed. Each rack location will contain at least 2 HV Bias Supplies, powering alternate BLM detectors. The BLM System can be tested by switching the HV bias power supplies off and on again. The resulting transient capacitively couples between the high voltage and signal electrode and through the BLM electronics, checking all components of the system, including the bias and signal cable continuity.

System calibration. Each BLM detector will be calibrated in a laboratory test setup using a static radiation source. Data will be taken throughout the operating voltage range for each detector. Testing will be done at BNL until the production is stable, with subsequent BLMs tested at ORNL. Insitu tests of the system through the installed cabling will be performed using a calibrated 1 G-Ohm resistor and voltage source for use in the calibration database.

Expected Losses

Experience at LAMPF and the PSR, and studies for APT at LANL⁷ have determined that losses of 1 W/m will allow hands-on accelerator maintenance (~100 mR/hr at 1 foot), with transverse losses primarily at quadrupoles where the beta-max occurs⁸. The beam-on dose rate can be estimated from the beam-off dose rate by a "rule-of-thumb": multipliers of 500-1000 are typically used. Taking 100 mR/hr at 1 foot as the beam-off activation, the beam-on dose rate may be estimated at 100 R/hr, or 0.46 mR/pulse, which is equivalent to 0.46 R/sec during the 1 msec beam.

The upper end limit has been specified as 1% local loss based on the expected losses in the Ring collimators⁹. The BLM system must generate a beam abort signal for the MPS in less than 10 μ sec. This will be done by integrating the beam loss during the macropulse and comparing the result to a programmable reference. Longer term losses at lower level can also do damage to beamline components. The numerically integrated output of each BLM will be compared to settable thresholds in the local processor. Excessive loss will generate an abort signal to the MPS through a VME utility module in the IOC crate. Still lower level losses, corresponding to the 100 mR/hr, 1 W/m loss will be similarly monitored and a software warning provided to the operators.

Detector

SNS will use 255 (Linac 88, HEBT 52, Ring 75, RTBT 40) argon-filled ion chambers as the primary detectors for monitoring beam losses. Argon has the advantage of fast electron transit time compared to slower air filled detectors¹⁰. The initial choice was an ion chamber designed by Shafer¹¹ at FNAL in 1982 for the Tevatron, and modified to improve radiation hardness and reduce noise for RHIC at BNL¹², but there was concern about saturation at high dose rate and long ion transit time (~ 700 μ sec at 2 kV bias). The ions, constituting 25% of the signal, would appear as a continued rise during the 1 msec pulse followed by a long ion tail after. However, processing could unfold the pulse shape. A new ion chamber, designed to overcome these limitations¹³, utilizes a larger inner diameter electrode to significantly decrease the ion transit time and raise the collection efficiency for a 1% local loss.

Figure 1 shows the measured response at the equivalent if a 0.05% local SNS loss in the 200 MeV BNL Linac to Booster beamline, for the FNAL and a new prototype detector with nitrogen fill. The slow rise during the beam pulse, and long tail

afterwards due to the ions is clearly seen for the FNAL detector. The “noise” is chopper modulation of the beam.

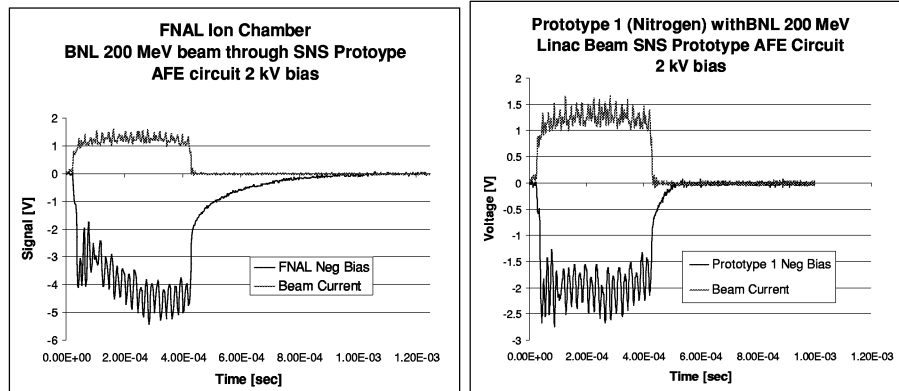

FIGURE 1. Beam Tests of the FNAL and New Prototype Ion Chambers

Installation

The detectors may be mounted directly to the beam pipe, magnet, or moved away from the radiation source to reduce signal output, allow a wider view over a larger area without intervening shielding. A typical SNS installation might raise the BLM 30 cm above the beam line on the upstream side of a quad. BLM’s will be placed so that successive units can have overlapping views to allow limited coverage in the event a channel fails. The system will be packaged so that adjacent detectors will not be placed on consecutive electronics channels in the same circuit module, where possible.

Some BLM’s may be exposed to X-rays from RF cavities. Measurements at BNL indicate that this may reach 50 R/hr during beam time. A study is needed to determine the type and amount of shielding required that would reduce the X-ray contribution to an acceptable level, and its effect on the beam loss measurement.

Cabling

Low tribo-electric RG-59 type cable such as Belden 9054 or 9224 will be used for the signals. Tribo-electric noise comes from friction between the conductors and insulation due to movement, such as vibration, but a low friction coating between insulator and conductors will reduce this significantly. Two HV cables (RG-59), from separate HV power supplies will connect to alternate BLM’s from each rack to provide some coverage in the event of a high voltage short or power supply failure.

ELECTRONICS

The BLM system will be distributed throughout the SNS. The controls electronics will be in VME, with analog signal conditioning housed in a non-VME crate in the

same rack. The analog crate will use linear rather than switching power supplies because of the very small signal currents. Figure 2 shows the system block diagram.

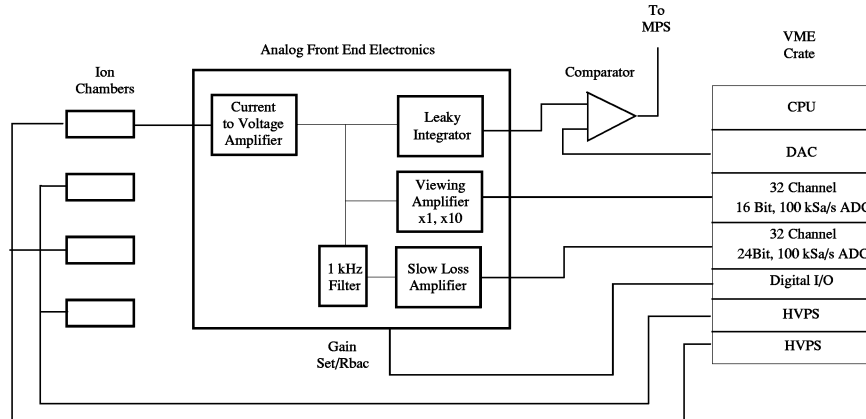

Figure 2. BLM System Block Diagram

System Dynamic Range Requirements

The BLM System must measure beam losses from a 1% local loss down to 1% resolution of a 1 W/m loss, a dynamic range of 126dB , or at least 21 bits. The design exploits the difference in bandwidth between these limits to allow additional resolution at the low end. During the 1 msec beam pulse the 1 W/m dose rate is estimated as 0.46 R/sec at 1 ft. For a typical BLM sensitivity of 70 nA/R/sec, this corresponds to 32.4 nA signal current during the pulse. The upper end loss, allowing for future improvements to 2 MW beam power, corresponds to 20 kW. Since the signal must inhibit the beam within 10 μ sec, only the electron signal will be considered, reducing the BLM sensitivity to 35 nA/R/sec. Then $I_{Max} = 16.2 \times 10^{-9} \times 2 \times 10^4 = 0.324$ mA for a loss of 1% uniformly during the 1 msec pulse.

Analog Front End Electronics

Figure 3 shows the AFE electronics schematic. The circuit provides 3 outputs to meet the fast trip, wideband-wide range data, and 1 W/m sensing requirements.

Wideband Signal Circuit

Since the ion chamber is a current source, the input resistor doesn't affect the signal gain but does determine the voltage noise gain and input signal risetime. A 100 m cable and 470 Ω resistor gives about a 5 μ sec risetime. A 6.2 k Ω feedback resistor puts the signal mid-range for 5 V ADC for a 1% beam loss. For the 35 kHz SNS BW, the 10 pA at 10 Hz BW noise observed in RHIC would correspond to 3.7 μ V. Three jumper selectable gains with readbacks are provided. "Viewing Gain" can be set and

read back remotely without affecting the beam interrupt or 1 W/m outputs. The signals of Figure 1 were made using this circuit.

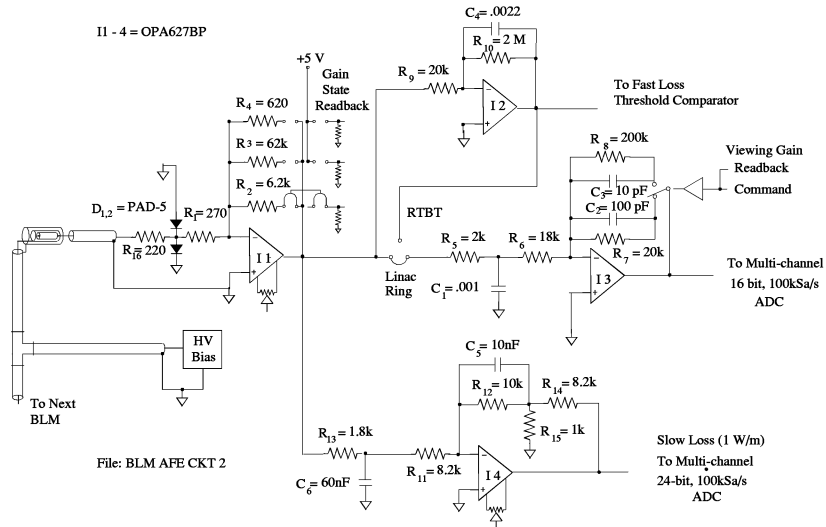

Figure 3. Analog front-end electronics schematic

The 1 W/m loss Circuit

A 1 W/m loss will produce 200 μV out of the input stage, roughly an LSB for a 5V, 16-bit (15-bit plus sign) ADC. Another 7-bits would be needed for 1 % resolution of a 1 W/m loss. Using a 1 kHz low pass filter, the noise would be reduced by the equivalent of almost 3-bits. Having an analog filter precede the output amplifier reduces the peak of short duration losses, allowing the additional gain of 10. A lower cut-off might not allow sufficient time to measure the baseline for offset subtraction. The output goes to a 24 bit, 100 kSa/sec ADC. Tests of one ADC (ICS-110B) indicate it can achieve 18-19 bit resolution. This is not quite enough for the 1% resolution, but sampling over 10 seconds or longer should provide the required sensitivity. Detailed testing of this and other ADCs, including thermal drift of offset and gain, is in process. Using measurements prior to the pulse, offsets of the AFE as well as the ADC, which are likely to be in excess of tens of microvolts, can be measured and subtracted. Dedication of one ADC channel to read a reference voltage may be required to compensate for gain thermal drift.

The Pulse Integrated Dose Circuit

Experience at LANSCE¹⁴ has shown that a beam inhibit signal should be based on integrated dose rather than dose rate. Thus an integrator will be used to provide a signal to a comparator to generate a signal for the MPS when the programmable reference is exceeded (see Figure 2). A gated integrator with a triggered reset would give a precise integral of the loss, but the gating, reset, and charge injection

compensation circuitry add considerable complexity to the design. A “leaky integrator”, using a large value resistor to bleed the charge, is simple and provides an adequate representation of the pulse dose. Simulations indicate that for an RC time constant of 1/3 the pulse period, the output will reach equilibrium in 3 beam pulses with an error of less than 10% while decaying to under 5% by the next beam pulse. This is a reasonable trade-off to the reduction of complexity and reliability of the triggered integrator.

Since the 695 nsec wide RTBT beam pulse would be too narrow for the 100 kSa/s ADCs to acquire through the wideband output, the signal from this integrator will be jumper selected for input to the Viewing Gain stage.

ACKNOWLEDGMENTS

The authors would like to R. Shafer and M. Plum of LANL for providing valuable insight and discussions regarding the topics in this work. The BNL staff includes Chaofeng Mi who built and tested the AFE circuit. Yongbin Leng evaluated the ADC's, John Smith has been invaluable in supporting the Controls aspect of this system. Tony Curcio, Paul Ziminski and members of the Instrumentation Group provided enthusiastic cooperation in building, testing and installation of the prototype detectors and circuits.

REFERENCES

-
- ¹ Alonso, J., "The Spallation Neutron Source Project", Proceedings of the 1999 PAC, NY, 1999, p574. For current status see <http://www.sns.gov>
 - ² Witkover, R. L., "Microprocessor Based Beam Loss Monitor System for the AGS", IEEE Trans. Nucl. Sci 26 3313 (1979)
 - ³ M. A. Clarke-Gayther, et al. "Global Beam loss Monitoring Using Long Ionisation Chambers at ISIS", 4th European Particle Accelerator Conference, London, England, 1994, p1634
 - ⁴ Witkover, R. L., Michnoff, R. J. and Geller, J. M., "RHIC Beam Loss Monitor System Initial Operation", Proceedings of the 1999 PAC, NY, 1999, 2247
 - ⁵ Bergoz Inc, <http://www.bergoz.com>
 - ⁶ Bai, M., et al., "RHIC Beam Loss Monitor System Commissioning in the Year 2000 Run", To be published these proceedings.
 - ⁷ Hardekopf, R. A., "Beam Loss and Activation at LANSCE and SNS", LA-UR-99-6825, Los Alamos National Laboratory, Los Alamos, NM. Sept. 1999
 - ⁸ Loc. Cit. Reference 7
 - ⁹ Y. Y. Lee, BNL, Private Communication, Oct 2001
 - ¹⁰ Plum, M., and Brown, D., "Response of Air-Filled Ion Chambers to High Intensity Radiation Pulses", Proceeding of the 1993 PAC, p2181
 - ¹¹ Shafer, R. E., et al., "The Tevatron Beam Position and Beam Loss Monitoring Systems", Proc. The 12th Int'l Conf. High Energy Accel., p609, 1983
 - ¹² Loc. Cit. reference 4.
 - ¹³ Witkover, R. L. and Gassner, D. "Design of an Improved Ion Chamber for the SNS", These proceedings
 - ¹⁴ Plum, M., and Shafer, R., Private communications.