



Features

- ☑ Compliant with IEEE 802.3z Gigabit Ethernet 1000BASE-LX PMD specifications
- ☑ Distance options of 10 km, 25 km, 40 km and 70 km using DFB lasers also available
- ☑ Eye Safe (Class I Laser Safety)
- ☑ Excellent EMI & ESD protection (optional extra EMI shield also available)
- ☑ Multi-sourced 10-pin (2x5) SFF (Small Form Factor) package style
- ☑ -40 °C to +85 °C Operating Temperature ("A" option)
- ☑ Duplex LC optical connector interface
- ☑ Single +3.3 V supply & LV-PECL DATA interface (AC coupling option also available)
- ☑ LV-TTL TX DISABLE input & RX SIGNAL DETECT output

Description

The DTR-1250-SM-LC and DTR-1250-SM-LS fiber optic transceivers offer a simple and convenient way to interface 1000BASE-LX Gigabit Ethernet boards running at 1.25 Gbaud to single mode and multimode fiber optic cables. In addition to option "L2" for the 5 km distance specified in IEEE 802.3z standard, five other options with longer distance capability with single mode fibers are offered. In option "L1", a 1300 nm Fabry Perot laser with higher power and narrower spectral width and center wavelength range is used to increase the distance to at least 10 km. In option "L0", an even higher power 1300 nm Fabry Perot laser is used to offer more optical power budget. In option "H3", a 1300 nm DFB laser and a high sensitivity receiver are used to increase the distance to over 25 km or 30 km (assuming worst case fiber loss of 0.4 dB/km and 0.35 dB/km respectively). In option "H5", a 1550 nm DFB laser and a high sensitivity receiver are used to increase the distance to over 35 km or 40 km (assuming worst case fiber loss of 0.3 and 0.25 dB/km respectively). Finally, in option "H7", a high power 1550 nm DFB laser and

an ultra high sensitivity receiver are used to increase the distance to 70 km (assuming fiber loss of 0.2 to 0.25 dB/km). All modules satisfy Class I Laser Safety requirements in accordance with the US FDA/CDRH and international IEC-825 standards.

The transmit and receive functions are contained in a narrow width two-row, 10-pin (2x5) package with a Duplex LC connector interface. The receptacle fits into an RJ-45 form factor outline. The 10-pin configuration is in conformance to a Small Form Factor (SFF) multisource agreement.

The transmitter and receiver DATA interface are differential direct-coupled LV-PECL. An alternate version with AC coupling interface is also available. An LV-TTL Transmitter Disable control input is provided. The receiver Signal Detect output interface is also LV-TTL.

The transceiver operates from a single +3.3V power supply over an operating temperature range of -5 °C to +70 °C and -40 °C to +85 °C ("A" option). The package is made of metal for excellent EMI shielding.

Absolute Maximum Ratings

Parameter	Symbol	Minimum	Maximum	Units
Storage Temperature	T_{st}	- 40	+ 85	°C
Operating Case Temperature	"A" option	- 40	+ 85	°C
	"Blank" option	- 5.0	+ 70	
Supply Voltage	V_{CC}	- 0.5	+ 6.0	V
Input Voltage	V_{in}	- 0.5	V_{CC}	V
Output Current	I_O	-	50	mA
Lead Soldering Temperature & Time	-	-	260°C, 10 sec	

DTR-1250-SM-LC/LS

Transmitter Electrical Interface (over Operating Case Temperature Range)

Parameter	Symbol	Minimum	Typical	Maximum	Units
Input HIGH Voltage ¹	V_{IH}	$V_{CC} - 1.165$	-	$V_{CC} - 0.700$	V
Input LOW Voltage ¹	V_{IL}	$V_{CC} - 1.950$	-	$V_{CC} - 1.475$	V
Transmitter Disable Voltage	V_{DIS}	$V_{CC} - 1.3$	-	V_{CC}	V
Transmitter Enable Voltage	V_{EN}	0	-	0.8	V

¹ For AC-coupled modules, the input voltage swing is 0.25 V minimum and 1.2 V maximum single-ended.

Receiver Electrical Interface (over Operating Case Temperature Range)

Parameter	Symbol	Minimum	Typical	Maximum	Units
Output HIGH Voltage (LV-PECL) ^{1,2}	V_{OH}	$V_{CC} - 1.10$	-	$V_{CC} - 0.90$	V
Output LOW Voltage (LV-PECL) ^{1,2}	V_{OL}	$V_{CC} - 1.84$	-	$V_{CC} - 1.60$	V
Output HIGH Voltage (LV-TTL)	V_{OH}	2.4	-	V_{CC}	
Output LOW Voltage (LV-TTL)	V_{OL}	0	-	0.8	
Output Current	I_o	-	-	25	mA

¹ With 50 ohm terminated to $V_{CC} - 2$ volt (for DC-coupled modules).

² For AC-coupled modules, the output voltage swing into 50-ohm load is 0.3 V minimum and 1 V maximum single-ended.

Electrical Power Supply Characteristics (over Operating Case Temperature Range)

Parameter	Symbol	Minimum	Typical	Maximum	Units
Supply Voltage	V_{CC}	3.13	3.3	3.47	V
Supply Current ¹	DC-coupled module	I_{CC}	-	150	mA
	AC-coupled module	I_{CC}	-	175	mA

¹ Supply current does not include termination.

Application Notes

DATA interface (DC-coupled modules):
The interface circuit for standard DC-coupled modules with direct-coupled LV-PECL interface is shown in Fig. 1. The Transmitter input has internal 50 ohm termination.

DATA interface (AC-coupled modules):
For modules with AC coupling option, both transmitter and receiver interface has internal bias, termination and AC coupling capacitor. The transmitter can be connected directly to the driving SERDES as shown in Fig. 2. The receiver can be connected directly to the external 50 ohm loads (termination resistor of the SERDES). For best performance, both DATA+ & DATA- should be used.

TX DISABLE: The transmitter is normally enabled (i.e. when the TX DISABLE control input is not connected or at LV-TTL logic LOW). When the TX DISABLE voltage is higher than $V_{CC} - 1.3$ V, the laser is turned off independent of the input data.

SIGNAL DETECT: The Signal Detect circuit monitors the level of the incoming optical signal and generates a logic LOW signal when insufficient photocurrent is produced. Its output is LV-TTL with no termination required.

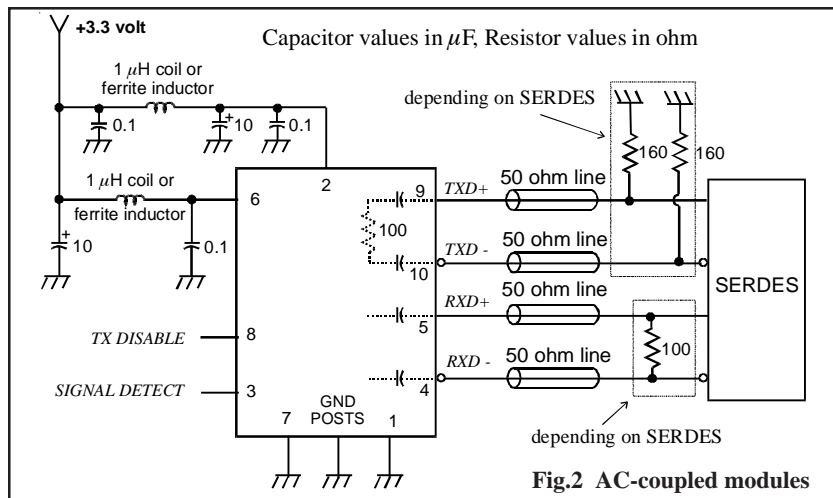
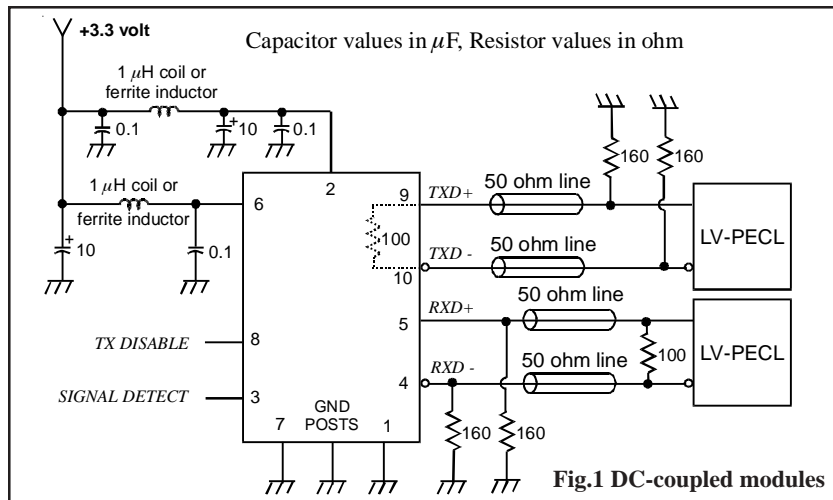

DTR-1250-SM-LC/LS

Transmitter Performance Characteristics (over Operating Case Temperature, $V_{CC} = 3.13$ to 3.47 V)

Parameter		Symbol	Minimum	Typical	Maximum	Units
Data Rate		B	125	1250	1300	Mb/s
Optical Output Power ¹	L2	P_o	- 11.0	-	- 3.0	dBm
	L1		- 9.0	-	- 3.0	
	L0		- 5.0	-	0	
	H3, H5		- 4.0	-	1.0	
	H7		- 3.0	-	2.0	
Center Wavelength	L2	λ_c	1270	1310	1355	nm
	L1, L0 (-5°C to 70°C)		1285	1310	1345	
	L1, L0 (-40°C to 85°C)		1274	1310	1360	
	H3		1280	1310	1335	
	H5, H7		1480	1550	1580	
Spectral Width (RMS) ¹	L2	$\Delta\lambda_{RMS}$	-	-	4.0	nm
	L1, L0		-	-	2.5	
Spectral Width (-20 dB)		H3, H5, H7	$\Delta\lambda_{20}$	-	-	1.0
Extinction Ratio		P_{hi}/P_{lo}	9	-	-	dB
Deterministic Jitter		DJ	-	-	80	ps
Random Jitter		RJ	-	-	147	ps
Relative Intensity Noise		RIN	-	-	- 120	dB/Hz
Transmitter Output Eye		compliant with Eye Mask Defined in IEEE 802.3z standard				

¹ Measured average power coupled into single mode fiber (SMF). For 50 μ m or 62.5 μ m multimode fiber (MMF) operation, the output power is 0.5 dB less and is measured after a single mode fiber offset-launch mode-conditioning patch cord as specified in IEEE 802.3z.

Receiver Performance Characteristics (over Operating Case Temperature, $V_{CC} = 3.13$ to 3.47 V)

Parameter		Symbol	Minimum	Typical	Maximum	Units	
Data Rate		B	1000	1250	1300	Mb/s	
Minimum Input Optical Power (10 ⁻¹² BER) ¹	L2, L1, L0	P_{min}	- 20.0	-	-	dBm	
	H3, H5		- 21.0	-	-		
	H7		- 23.0	-	-		
Maximum Input Optical Power (10 ⁻¹² BER) ¹		P_{max}	- 3.0	-	-	dBm	
Signal Detect Thresholds	Increasing Light Input	P_{sd+}	L2, L1, L0	-	-	- 20.0	dBm
			H3, H5	-	-	- 21.0	
			H7	-	-	- 23.0	
	Decreasing Light Input	P_{sd-}	- 30.0	-	-	dBm	
Signal Detect Hysteresis		-	0.5	-	-	dB	
Deterministic Jitter		DJ	-	-	170	ps	
Random Jitter		RJ	-	-	96	ps	
Wavelength of Operation		λ	1100	-	1600	nm	
Return Loss		-	12	-	-	dB	
Electrical 3 dB upper cutoff frequency		-	-	-	1500	MHz	
Stressed Receiver Sensitivity		compliant with IEEE 802.3z standard					

¹ Measured with 2⁷-1 PRBS at 1250 Mb/s at 1300 nm wavelength.

Power supply and grounding: The power supply line should be well-filtered. All 0.1 μ F power supply bypass capacitors should be as close to the DTR transceiver module as possible. The two front GND posts (mounting studs) should be grounded to Chassis Ground for best EMI and ESD protection. If Chassis Ground is not available, they should be tied to Circuit Ground.

Transmission distance: The transmission distances indicated for the H3, H5 and H7 modules with DFB laser options are guidelines only, not guaranteed. The exact distance is dependent on the particular fiber loss involved and can be calculated from the optical loss budget.

DTR-1250-SM-LC/LS

Package without EMI shield (LC)

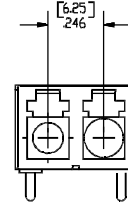
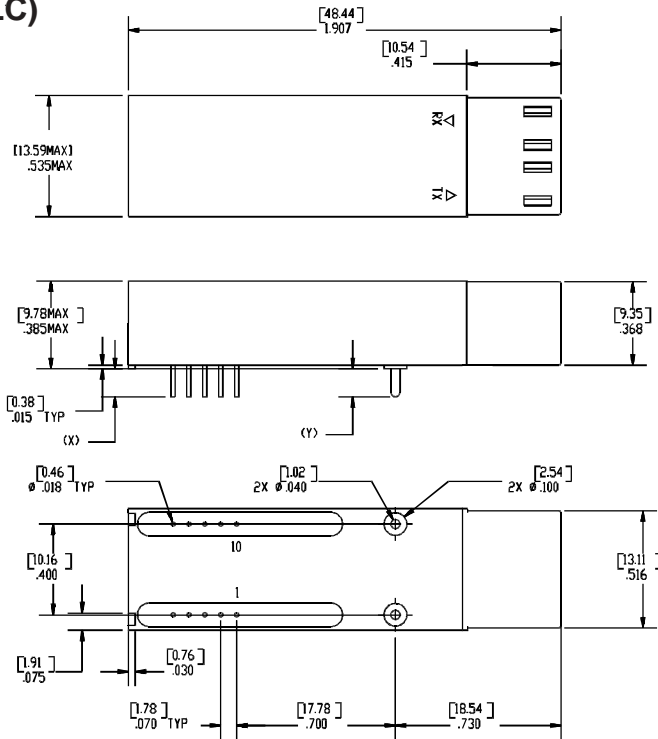

Dimension in inches [mm]

Package with EMI Shield (LS)

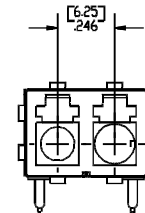
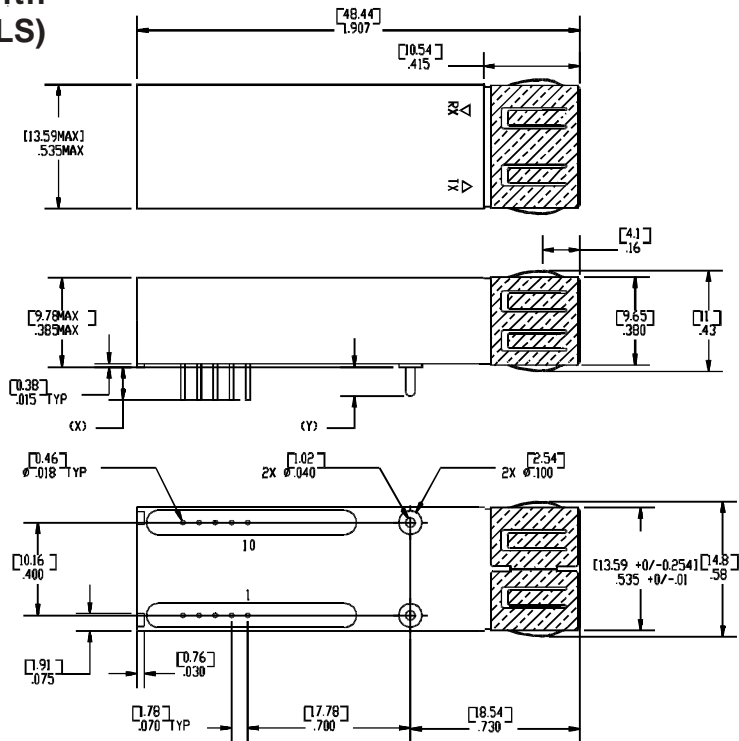

Dimension in inches [mm]

Notes:

- Default tolerance for all dimensions given in inches (Unless otherwise noted)
 .xxx = ± 0.005
 .xx = ± 0.01
- x, y: see Pin length option table in ordering information

DTR-1250-SM-LC/LS

Pin Assignments

PIN	FUNCTION
1	RX GND
2	V _{cc} RX
3	SD (RX SIGNAL DETECT)
4	RD- (RX DATA OUT -)
5	RD+ (RX DATA OUT +)
6	V _{cc} TX
7	TX GND
8	TX DISABLE
9	TD+ (TX DATA IN +)
10	TD- (TX DATA IN -)

Laser Safety: All transmitters are Class I Laser products per FDA/CDRH and IEC-825 standards. They must be operated under specified operating conditions.

Optical Communication Products, Inc.

DATE OF MANUFACTURE:

MANUFACTURED IN THE USA

This product complies with
21 CFR 1040.10 and 1040.11

Meets Class I Laser Safety Requirements

Ordering Information

DTR-1250 - SM - WW - T - Xn - YY - Mp

Package Types

LC: Package without Shield
LS: Package With Shield

Temperature Range

“Blank”: -5 °C to 70 °C
“A”: -40 °C to 85 °C

Coupling option

“Blank”: DC coupling
AC : AC coupling

*see Pin Length
option table*

Light Output Power

L2: -7dBm (typ.), (5km)
L1: -6dBm (typ.), (10km)
L0: -3dBm (typ.), (10km)
H3: -1dBm (typ.), (25 km w/ 1300 nm DFB laser)
H5: -2dBm (typ.), (40 km w/ 1550 nm DFB laser)
H7: -1dBm (typ.), (70 km w/ 1550 nm DFB laser)

Pin Length option table

Options (p)	Pin Length (x)		Post Length (y)	
	Inches	Millimeters	Inches	Millimeters
"blank"	0.140 ± 0.010	3.56 ± 0.250	0.125 + 0.010 - 0.005	3.17 + 0.250 - 0.125
5	0.155 ± 0.010	3.94 ± 0.250	0.155 + 0.010 - 0.005	3.94 + 0.250 - 0.125
8	0.180 ± 0.010	4.57 ± 0.250	0.180 ± 0.010	4.57 ± 0.250

Note:

- When “A” option is required for H5 and H7 power output, it is only available over temperature range of -25°C to +70 °C.
- These are target distances to be used for classification and not for specification.

Optical Communication Products, Inc.

20961 Knapp Street, Chatsworth, CA 91311, Tel.: 818-701-0164, FAX: 818-701-1468, <http://www.ocp-inc.com>

Optical Communication Products, Inc. reserves the right to make changes in equipment design or specifications without notice. Information supplied by Optical Communication Products, Inc. is believed to be accurate and reliable. However, no responsibility is assumed by Optical Communication Products, Inc. for its use nor for any infringements of third parties which may result from its use. No license is granted by implication or otherwise under any patent right of Optical Communication Products, Inc.

Contents

Description	1
Absolute Maximum Ratings	1
Transmitter Electrical Interface (over Operating Case Temperature Range)	2
Receiver Electrical Interface (over Operating Case Temperature Range)	2
Electrical Power Supply Characteristics (over Operating Case Temperature Range)	2
Application Notes	2
Transmitter Performance Characteristics (over Operating Case Temperature)	3
Receiver Performance Characteristics (over Operating Case Temperature)	3
Package without EMI shield (LC)	4
Package with EMI Shield (LS)	4
Ordering Information	5