

Sector 12:
Identification of “sensitive areas”
for helium spill

L. Tavian, 28 August 2014

Sector 12 overview

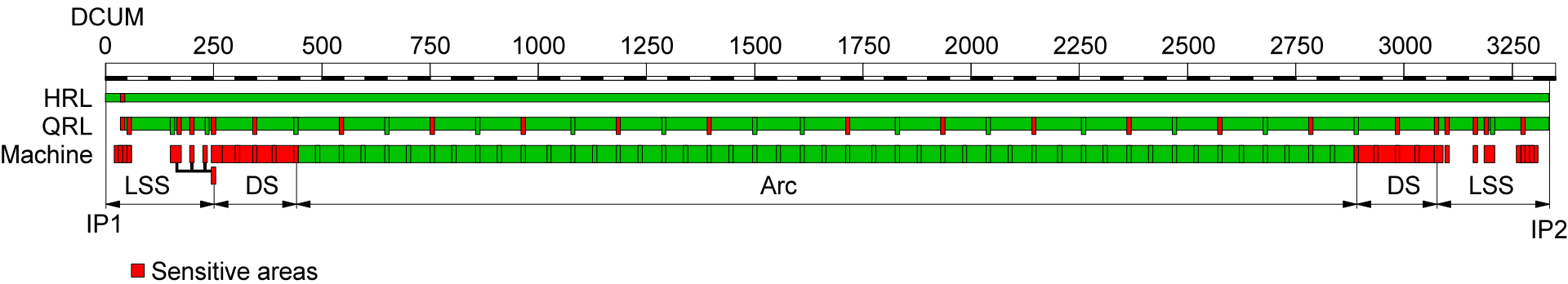

DFBxB R1 DCUM 55 m QRLIB (return module)

UJ16

UJ16 UJ17

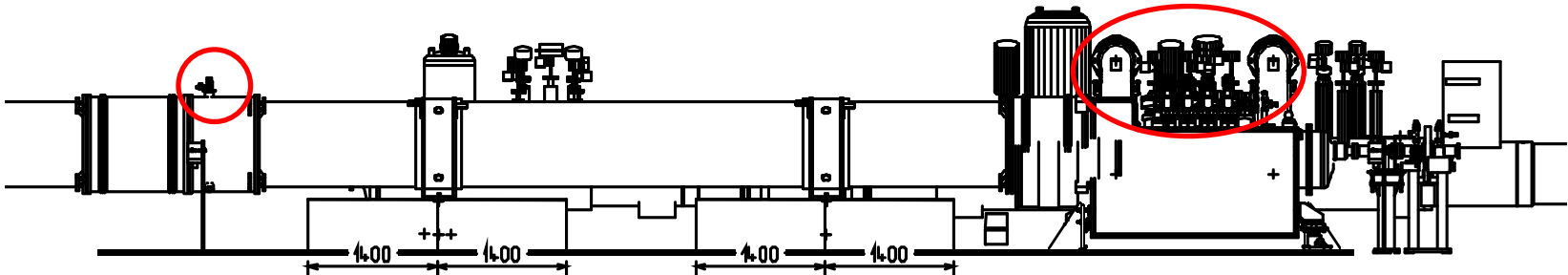

QRLIB

QRLGC

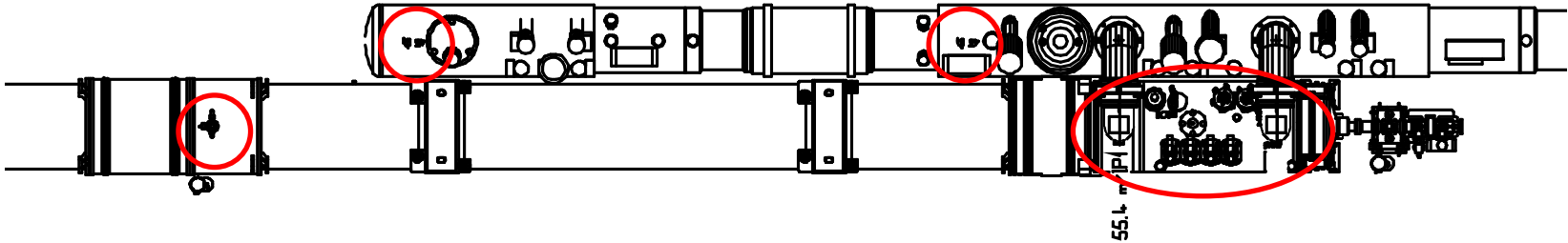

D2Q4R1 DCUM 172 m

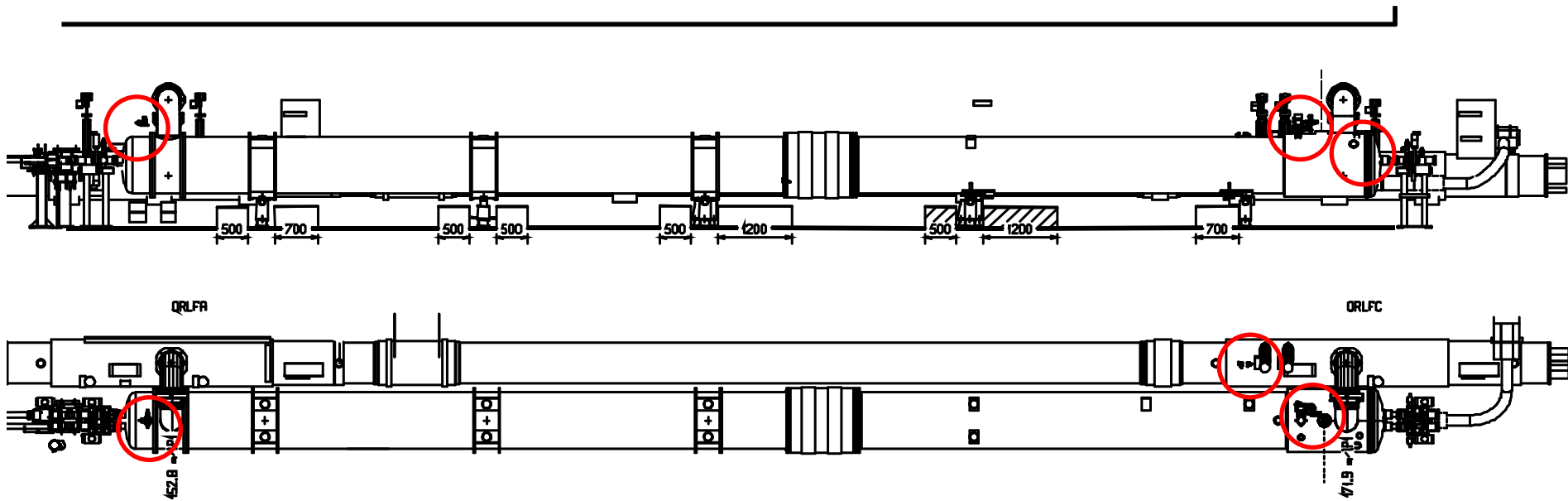

Q5R1 DCUM 200 m

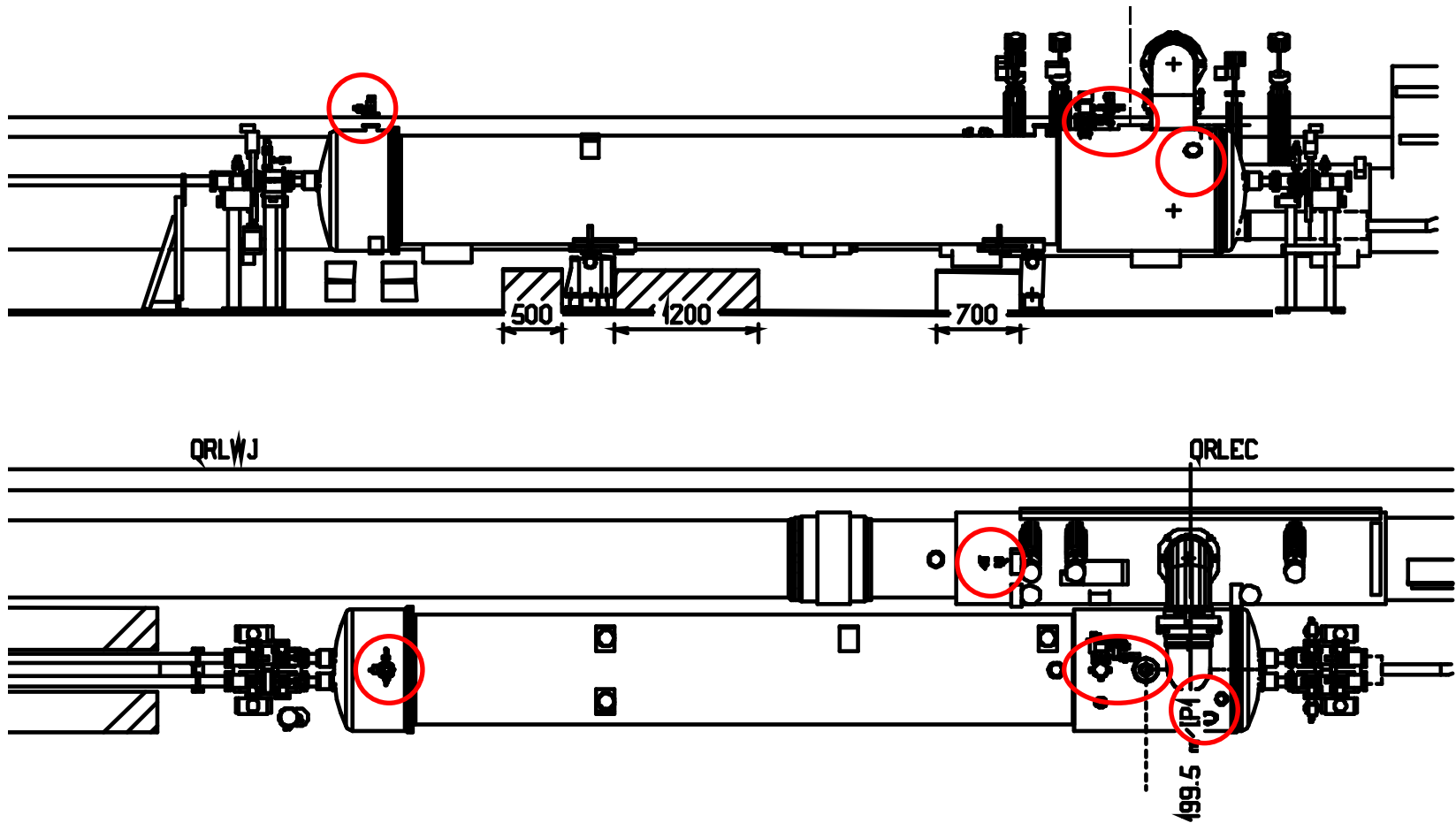

Q6R1 DCUM 231 m

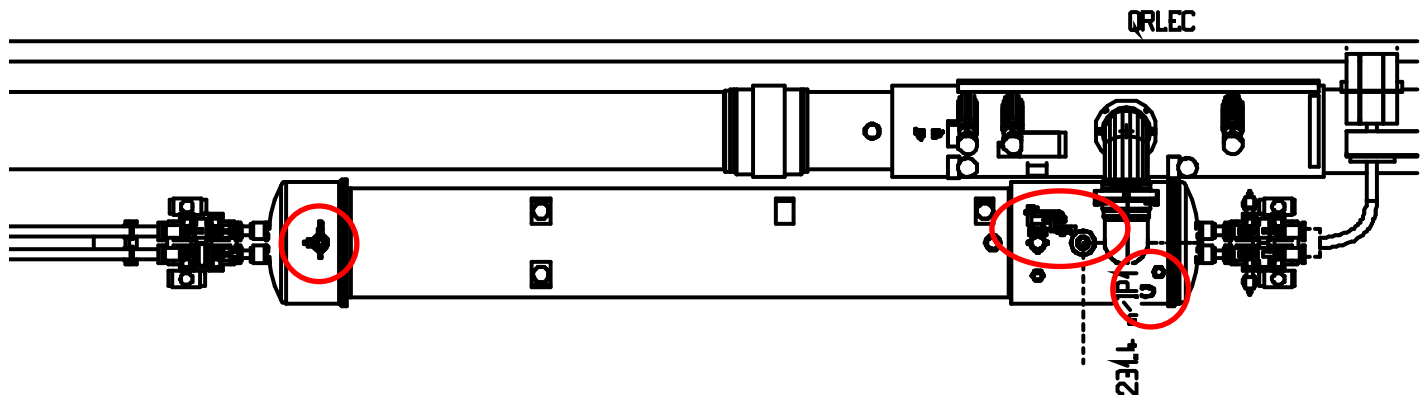
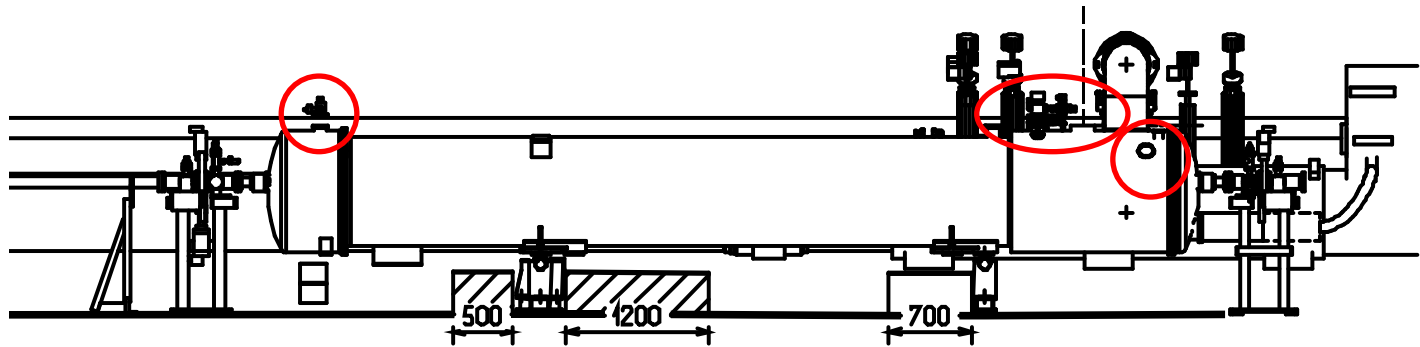

DFBAB R1 DCUM 250 m

RR17

RR17

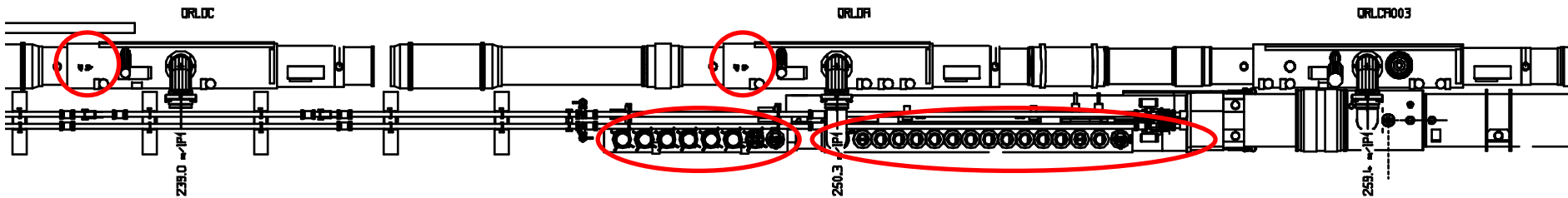
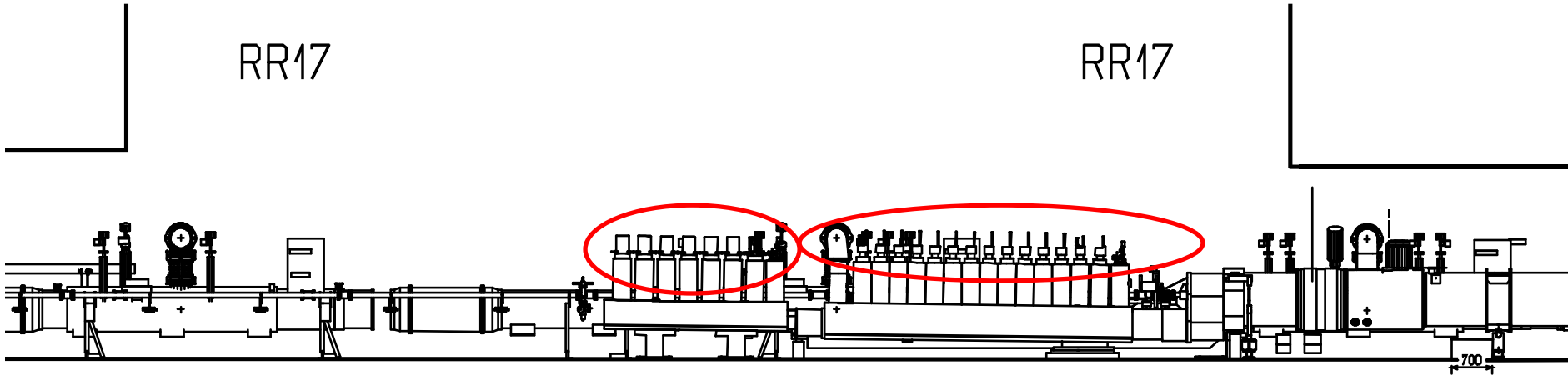

DFBLB in RR17 DCUM 250 m

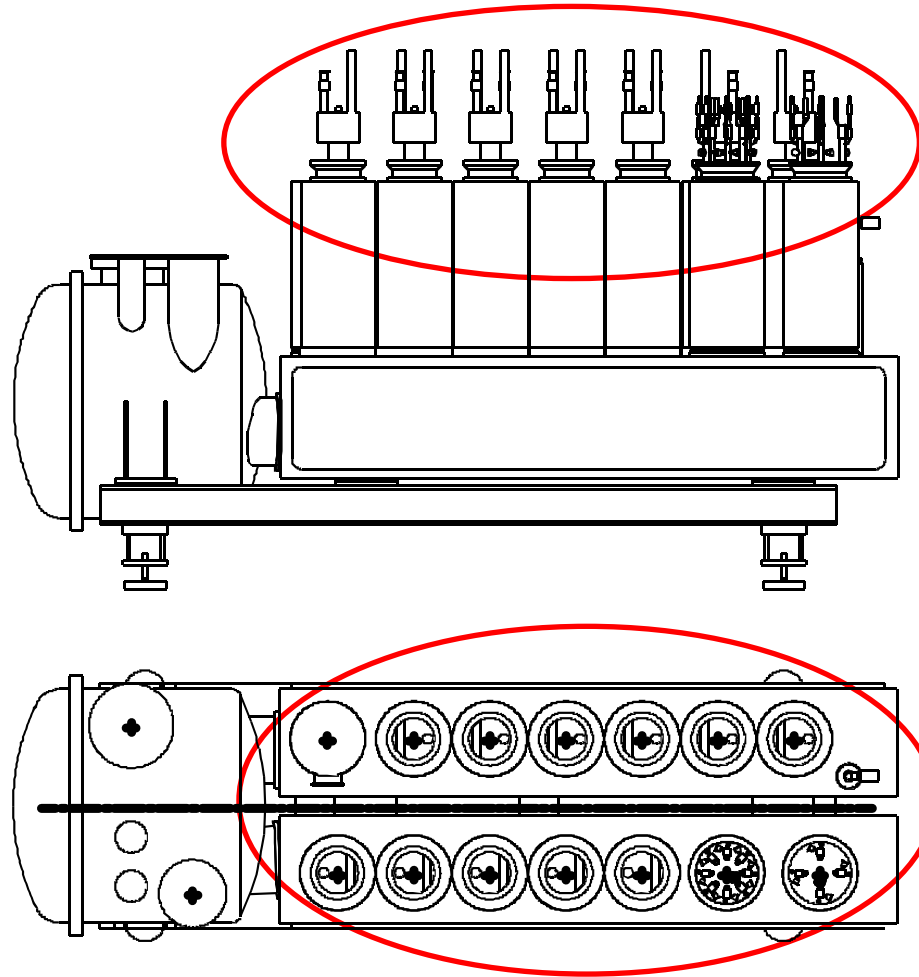

Q9R8 DS DCUM 340 m

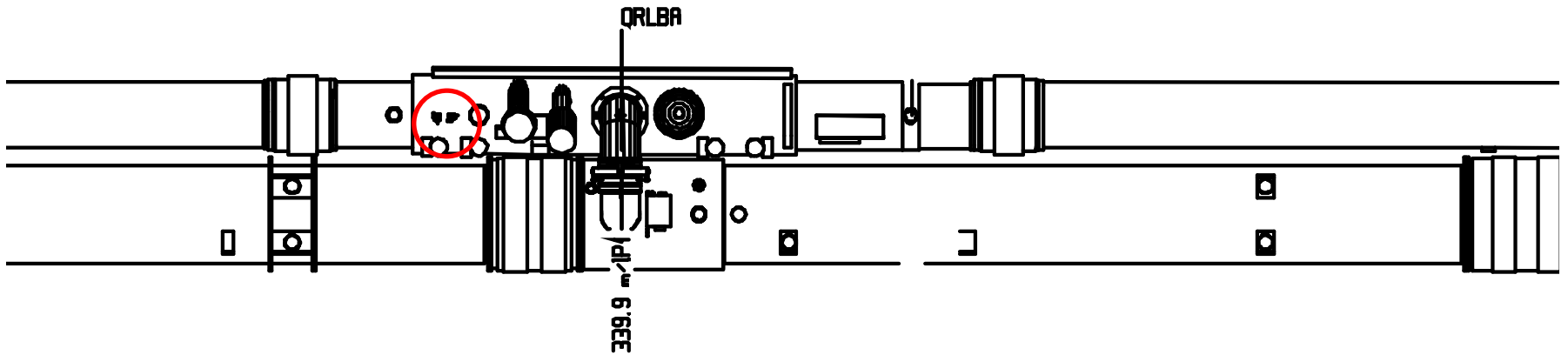
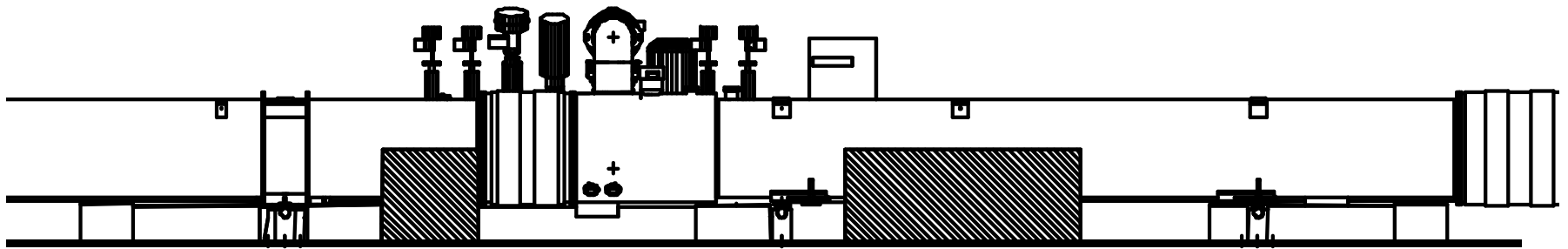

QRLAA service module in the Arc12

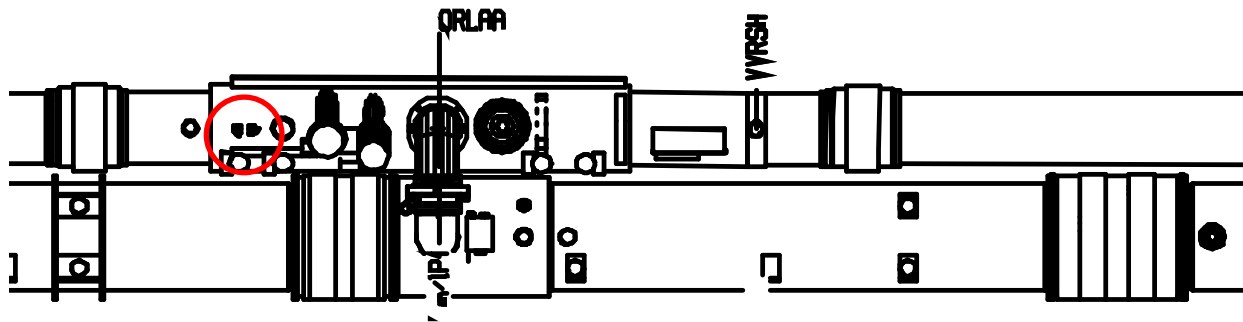
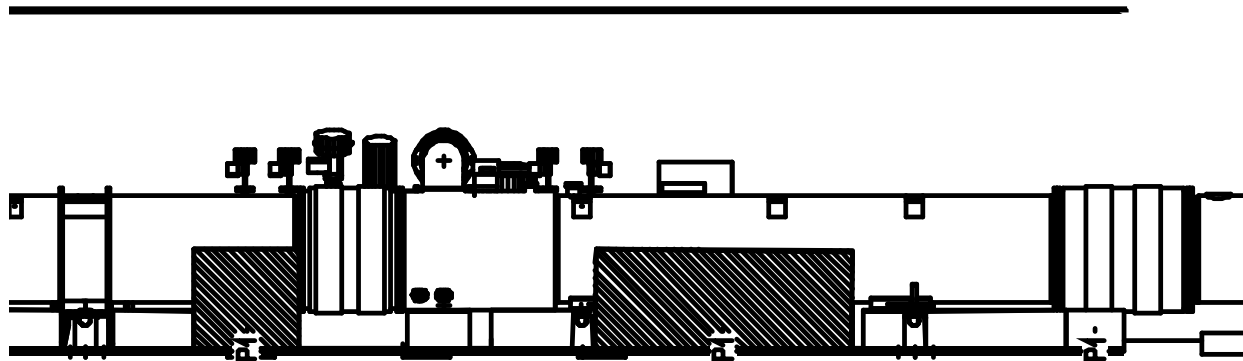

- Q13R1 DCUM 541 m
- Q17R1 DCUM 755 m
- Q21R1 DCUM 969 m
- Q25R1 DCUM 1183 m
- Q29R1 DCUM 1397 m
- Q33L2 DCUM 1717 m
- Q29L2 DCUM 1931 m
- Q25L2 DCUM 2145 m
- Q21L2 DCUM 2359 m
- Q17L2 DCUM 2573 m
- Q13L2 DCUM 2786 m

Q9L2 DS DCUM 2984 m

R22

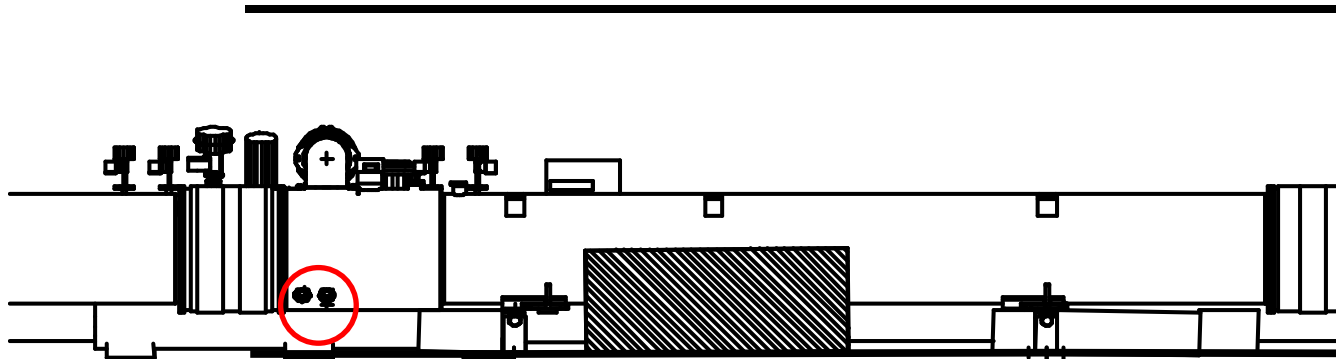

ORLBA

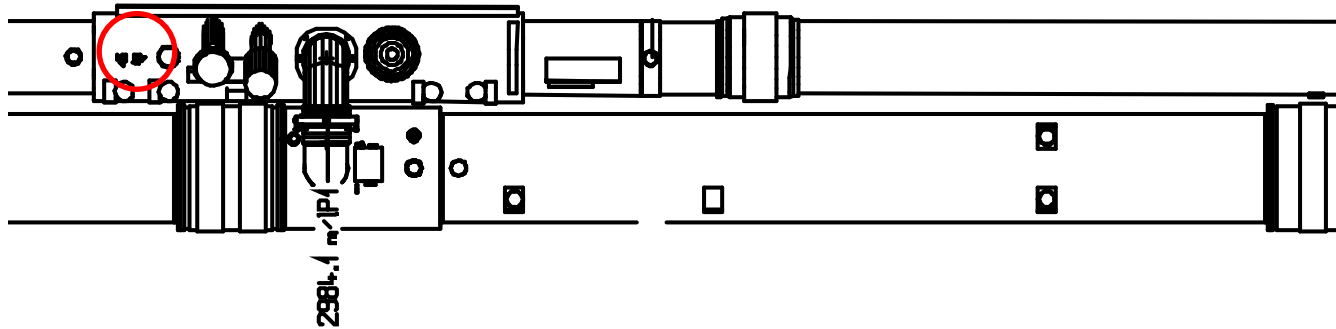

DFBAC L2 DCUM 3075 m

UJ23

RH23

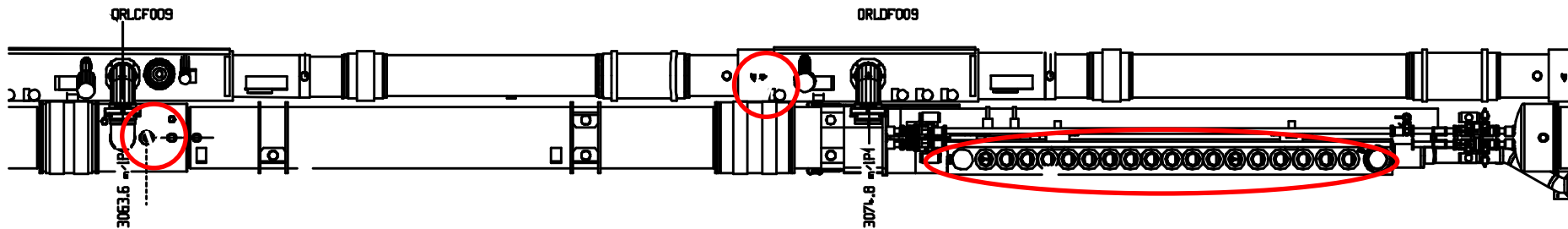
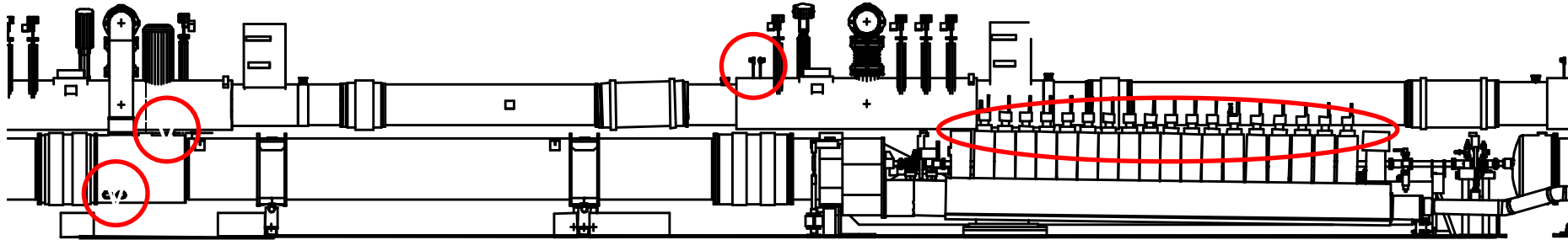

Q6L2 DCUM 3087 m

RH23

RA23

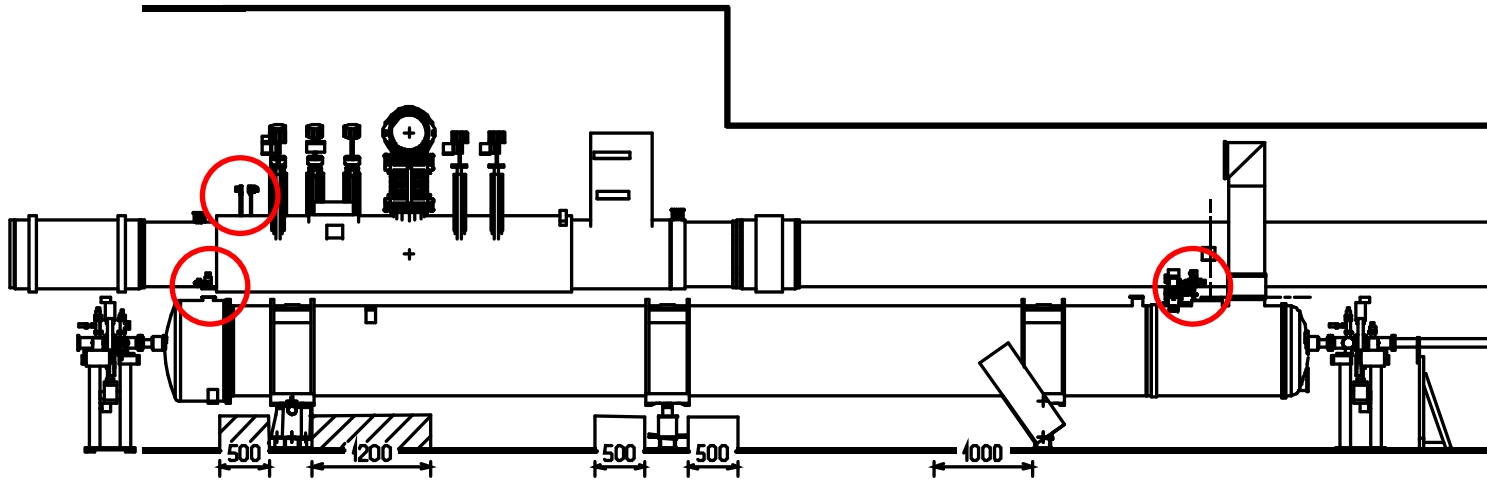

DRLEA004

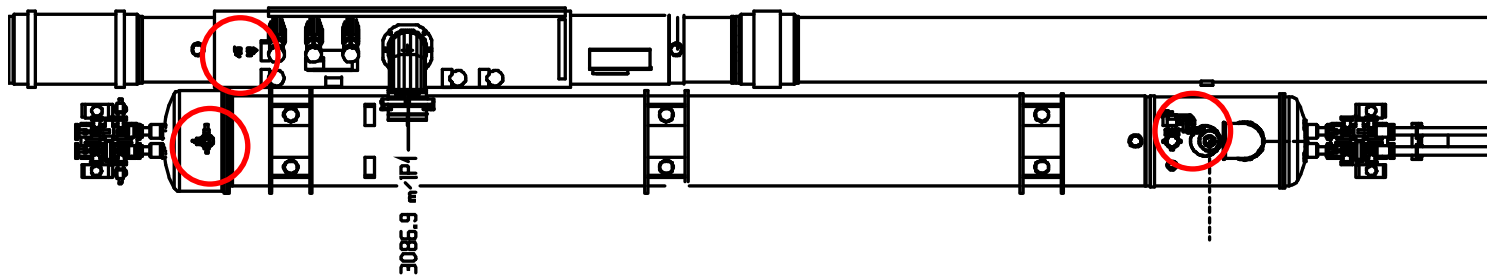

Q5L2 DCUM 3167 m DFBMC

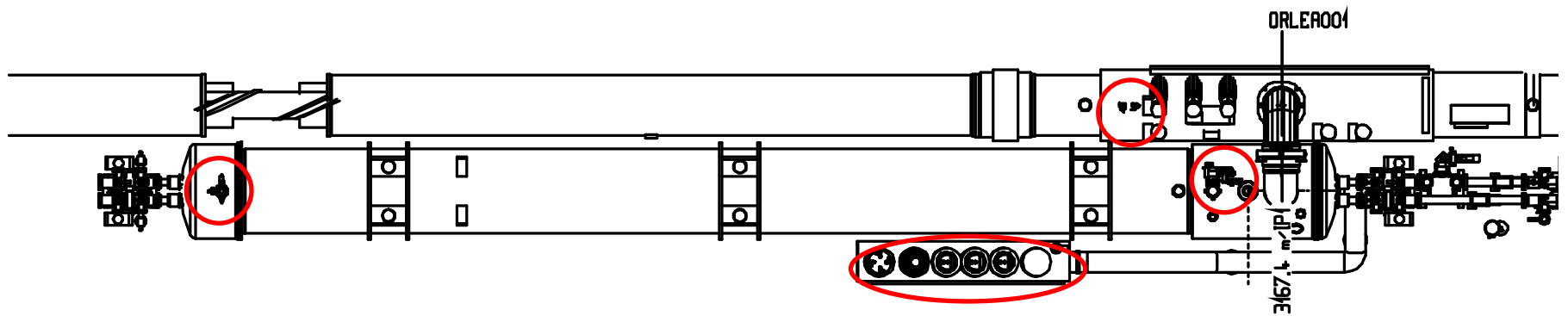
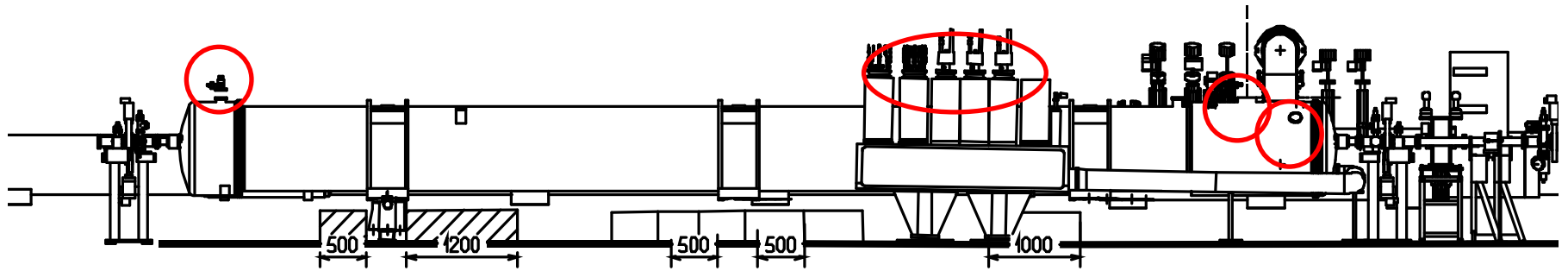

Q4D2L2 DCUM 3189 m DFBMA

RA23

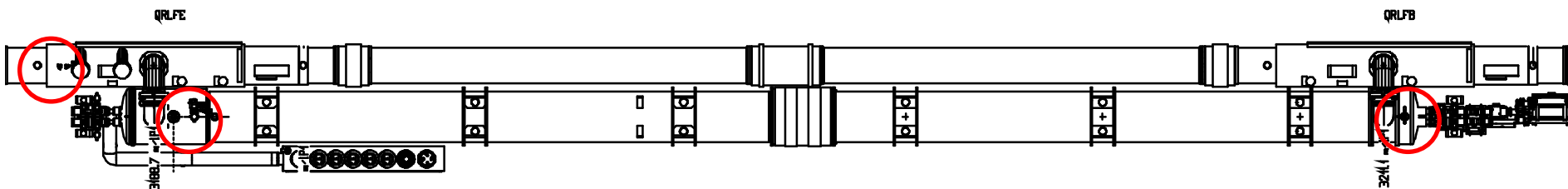
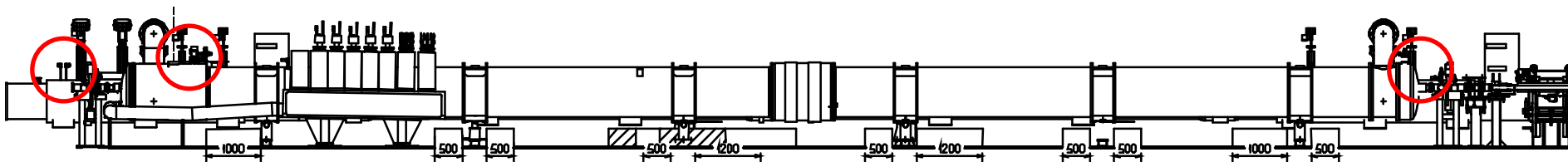

DFBXC L2 DCUM 3275 m

